

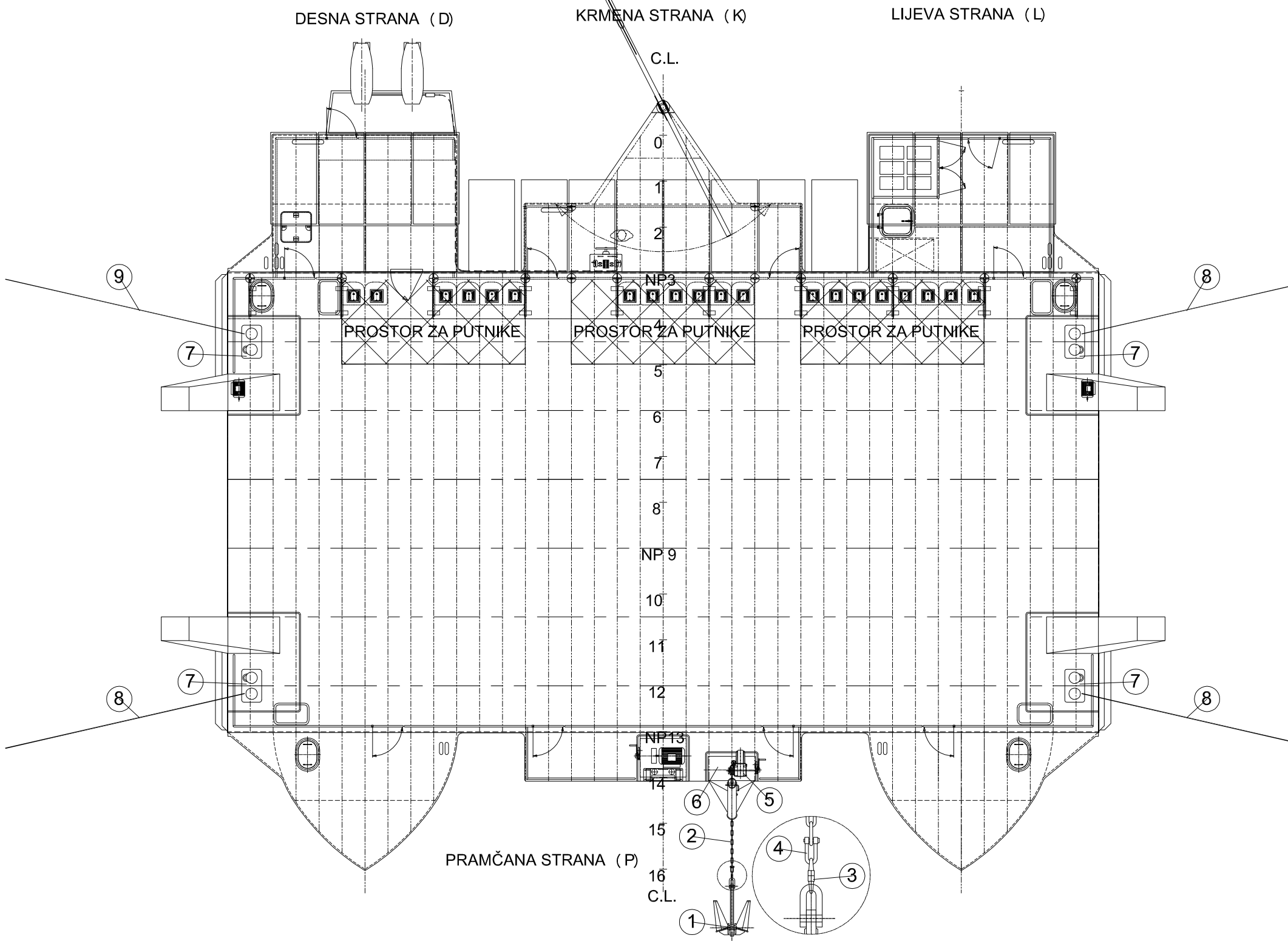

M. W L

GRADITELJ:									
OBJEKT: SKELA KRIŽNICA									
				Datum	Ime	Naziv nacrtat:		Mjerilo:	
				Projektirao	02.05.2019	Lj.Čubrilo, dipl.Ing.	VEZ I SIDRENJE		1:100
				Činilo	02.05.2019	Lj.Čubrilo, dipl.Ing.			
				Korisnik					
A	Uklanjanje osadine Rosa 2 Povećanje površine slike. Povr. 2.3.4.	19.09.2019	Lj.Čubrilo, dipl.Ing.	STIL d.o.o.		Broj nacrtat: 18/1/1/430/00-A3		List Broj: 1 Od: 4	Izdanje: A
Index	Izmjene	Datum	Ime	FILOMAR d.o.o.		Broj projekta: 10067/18A			

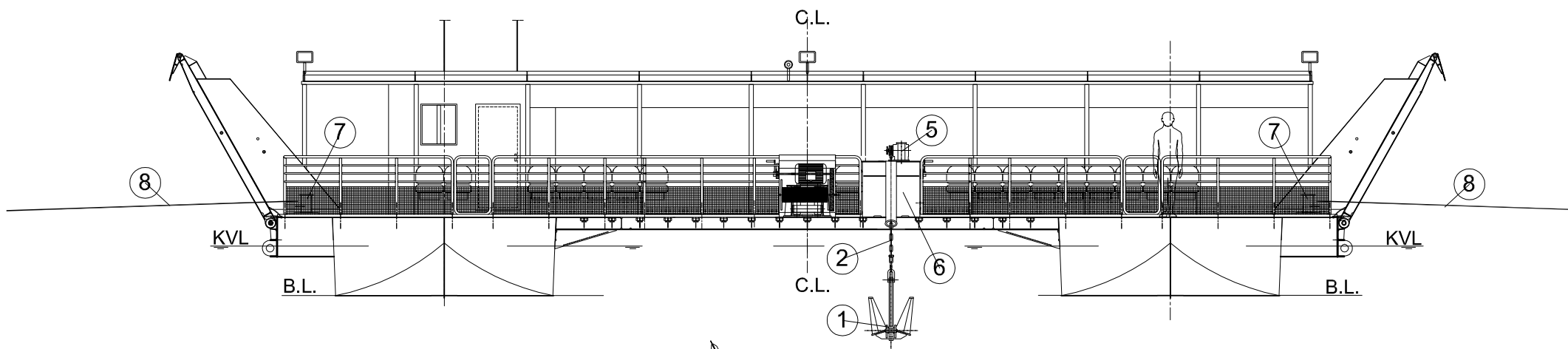

M. W L

9	1	PRIVEZNI KONOP	SUKANI POLIESTER	Ø24, 27m	PREKIDNA SILA 78,5kN	
8	2	PRIVEZNI KONOP	SUKANI POLIESTER	Ø24, 40m		
7	4	DVOSTRUKA BITVA	Č 0461			
6	1	LANČANIK	Č 0461		VEZA Nc.B:18/1/4/430/00-A3	
5	1	RUČNO SIDRENO VITLO	Č 0562		RACNA SILA 1,12kN BRZINA PRIVLAČENJA 0,12m/s	
4	2	SIDRENI ŠKOPAC	SB 1048	Ø16	TOPLO CINCAN, PREK.SILA 129kN	
3	1	VRTULJAK	SB 1051	CRS-L1	Ø16	
2	1	SIDRENI LANAC	DIN 763	CRS-L1	40m, Ø16, 4,25kg/m	TOPLO CINCAN, PREK.SILA 129kN
1	1	SIDRO	Č 0461	145kg	TIP HALL	
POZ.KOM		NAZIV	STANDARD	MATERIJAL	VELIČINA/MASA	NAPOМЕНА
GRADITELJ:						
OBJEKT: SKELA KRIŽNICA						
		Datum	Ime	Naziv nacrt:		Mjerilo:
		02.05.2019	Lj.Čubrilo.dlp.Ling.	PLAN SIDRENJA I VEZA		1:100
		02.05.2019	Lj.Čubrilo.dlp.Ling.			
Mjerna oznaka: 19.09.2019, Lj.Čubrilo.dlp.Ling.		STIL d.o.o.		Broj nacrt: 18/1/1/430/00-A3		Izdavanje: A
Povećane pretisne slike: Eoz.2.3.4		FILOMAR d.o.o.		Broj projekta: 10067/18A		
Index	Izmjene	Datum	Ime			

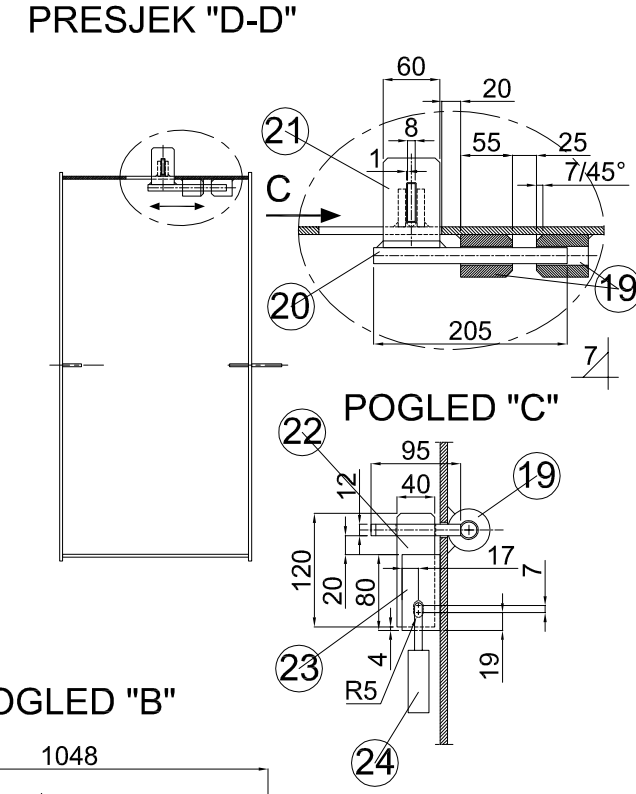
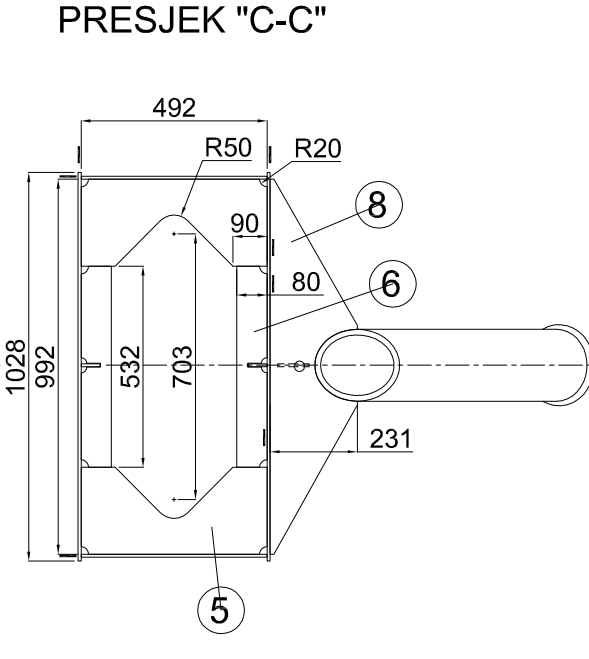
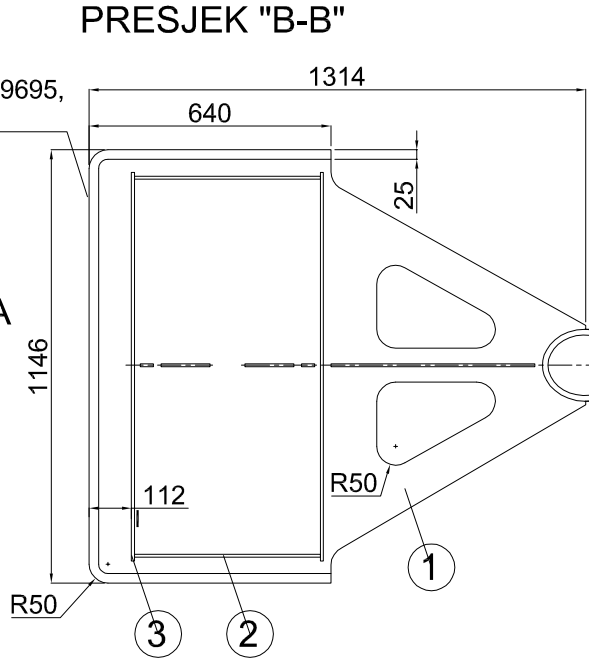
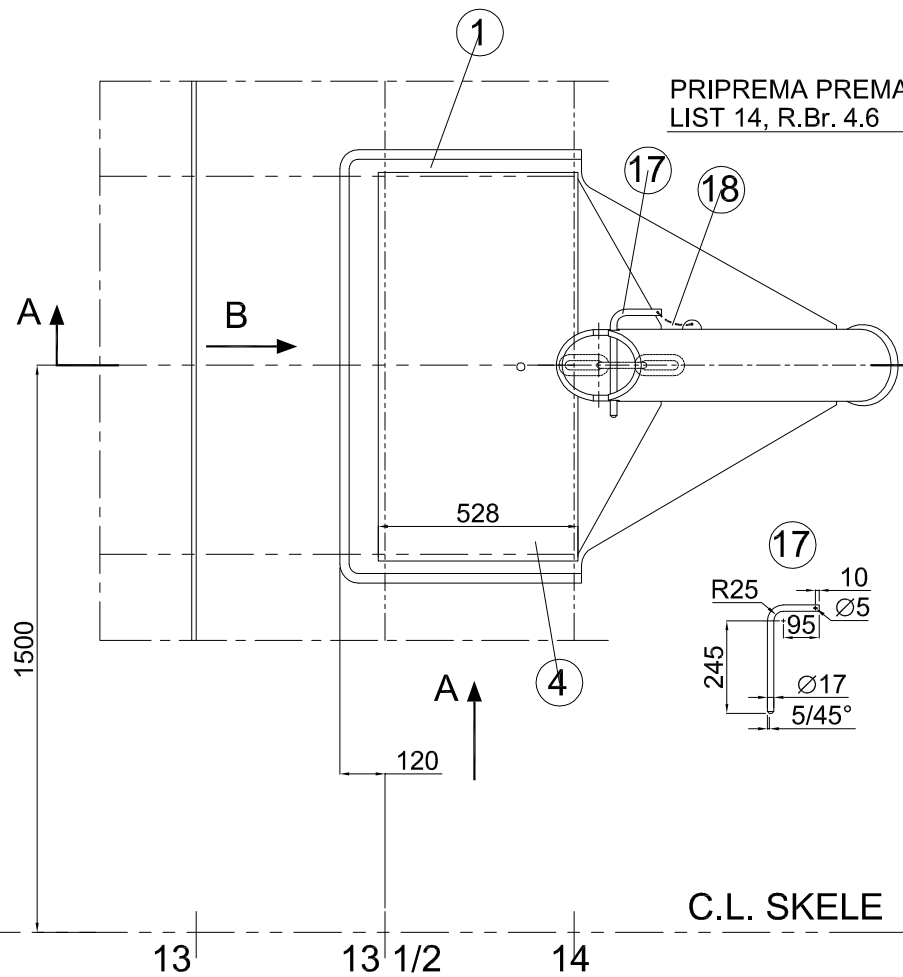

POGLED "A"

POGLED "B"

POGLED "C"

C.L. SKELE

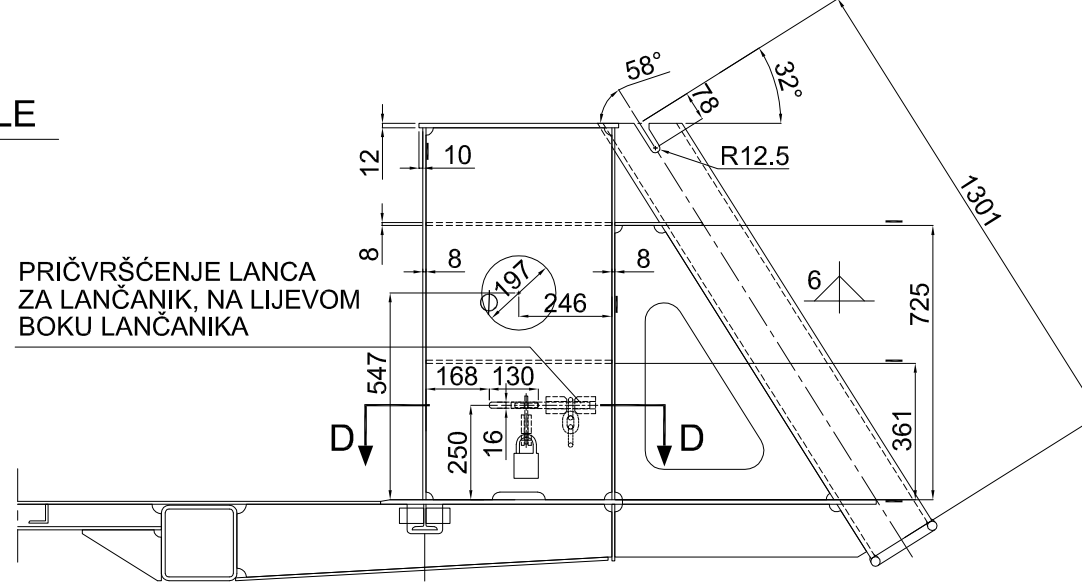

PRIČVRŠĆENJE LANCA ZA LANČANIK, NA LIJEVOM BOKU LANČANIKA

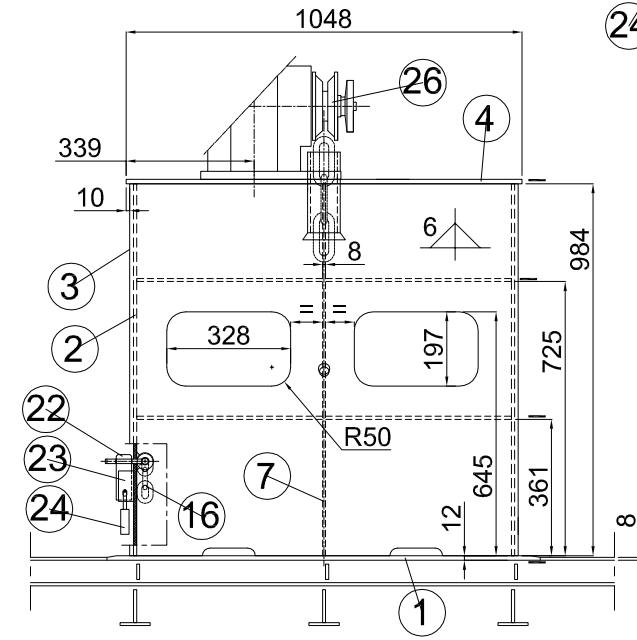

PRESJEK "A-A"

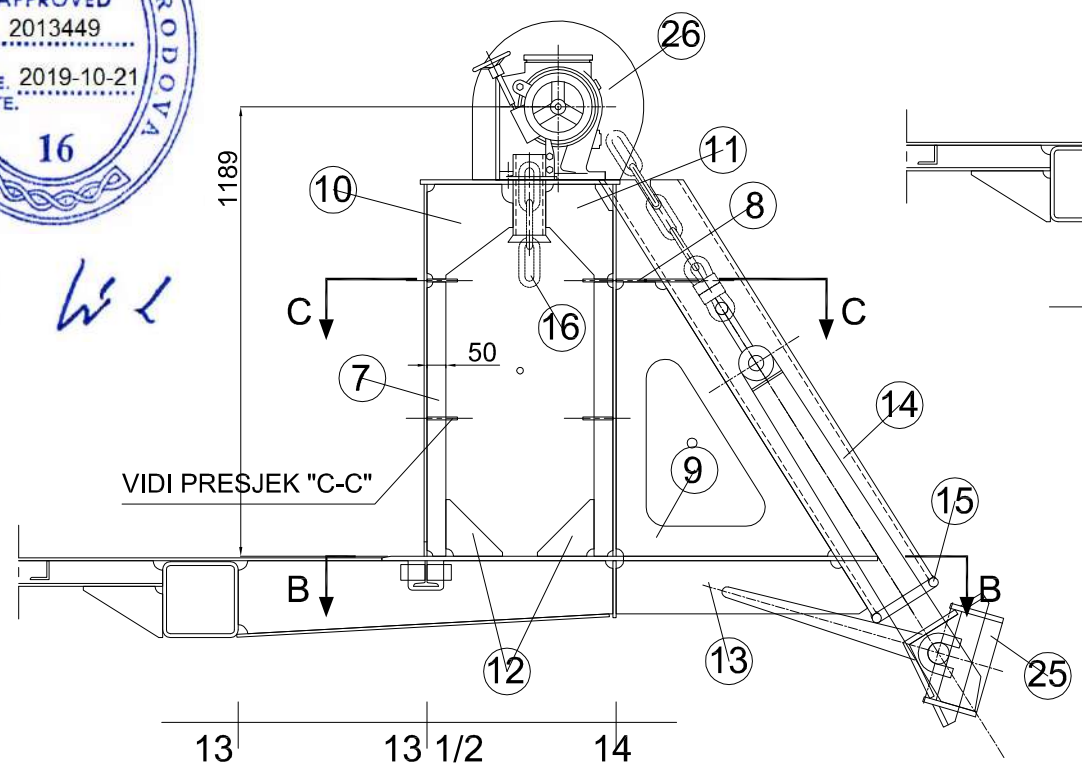

SIDRO TIP HALL

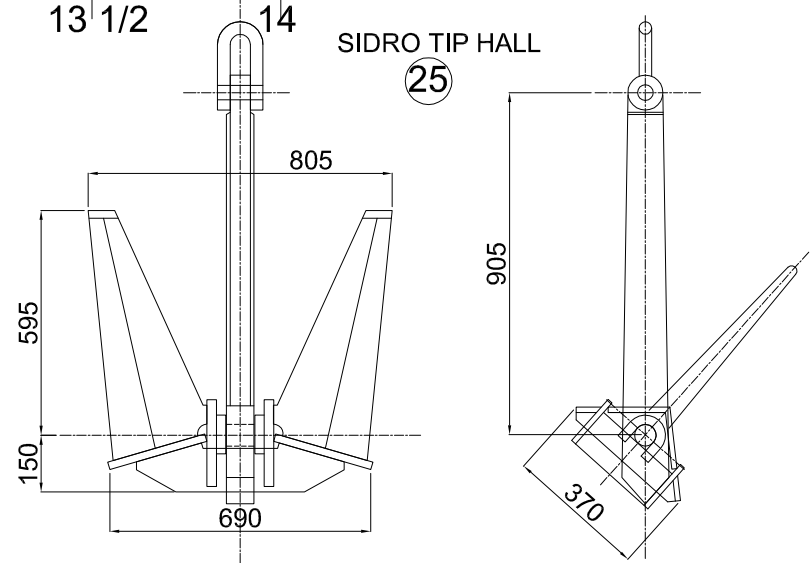

M. W L

AKZ : SB 9345

POZ	KOM	NAZIV	STANDARD	MATERIJAL	VELIČINA/MASA	NAPOMENA
26	1	RUČNO SIDRENO VITLO				
25	1	SIDRO	CRS "A"		145 kg	RAVNA SILA 8 109N, BEZNA POVLACENJA 0,15m/s
24	1	LOKOT REZE				TIP HALL
23	2	DRŽAČ OSIGURAA REZE	Č. 0461			
22	1	OSIGURAA REZE	Č. 0461			
21	1	RUČIA REZE	Č. 0461			
20	1	MUŠKI DIO REZE	Č. 0461		Ø17	
19	2	ŽENSKI DIO REZE	Č. 0461		Ø45x12,5	
18	1	ČUVAR DRŽAČA LANCA	DIN 766	CRS-L1	Ø4	LANČIĆ DULJINE 0,5m
17	1	DRŽAČ LANCA	CRS "A"		Ø17	
16	1	SIDRENI LANAC	DIN 763	CRS-L1	40m, Ø16, 4,25 kg/m	TOPLO CINCANI, PREK.SILA 107kN
15	1	USNA SIDRENOG ŽDRUJELA	CRS "A"		Ø25	
14	1	SIDRENO ŽDRUJELO	CRS "A"		Ø190x12,5	
13	1	UPORA	CRS "A"		t=8mm	
12	2	KOLJENO	CRS "A"		150x150x8	
11	1	KOLJENO	CRS "A"		251x178x8	
10	1	KOLJENO	CRS "A"		251x228x8	
9	1	TRAPEZNI NOSAČ SIDRENOG ŽDRUJELA	CRS "A"		t=8mm	
8	1	GORNJI OSLONAČ SIDR.ŽDRUJELA	CRS "A"		t=8mm	
7	2	USPRAVNA UKREPA	CRS "A"		#50x8	
6	4	VODORAVNA POPREČNA UKREPA	CRS "A"		#80x8	
5	4	VODORAVNA UKREPA BOKA	CRS "A"		t=8mm	
4	1	GORNJA PLOČA LANČANIKA	CRS "A"		t=12mm	
3	1	KRMENI ZID LANČANIKA	CRS "A"		t=8mm	
2	2	BOČNI ZID LANČANIKA	CRS "A"		t=8mm	
1	1	TEMELJ LANČANIKA	CRS "A"		t=12mm, 96 kg	

OBJEKT: SKELA KRIŽNICA

Index	Izmjene	Datum	Ime	Naziv nacrt:	Mjerilo:
				OPREMA ZA SIDRENJE POSTOLJE SIDR. VITLA LANČANIK I SIDRO	1:20
A	Dopuna Poz.16	19.09.2019.	Lj.Čubrilo.dtp.Ling.	STIL d.o.o.	
				18/1/4/430/00-A3	
				FILOMAR d.o.o.	